

# CamBolt for Vibrating Screens

For many years **Technofast** has provided accurate, safe and reliable bolt tensioning equipment to the Australian Mining Industry.

In line with our commitment to always seek to provide cost effective solutions to our market, we have developed a new concept for attaching the exciter mechanism to a variety of vibrating screens used in mineral processing plants.

Based on our highly effective A3 CamNut, we now introduce the **Technofast CamBolt**.

The **CamBolt** System is safe to use and removes the possibility of "Pinch Point Injuries" which can occur when using torque devices. Operation is fast and simply resulting in cost benefits when compared to other bolt tightening methodologies.

The **CamBolt** System is readily reusable and can be fitted in both blind hole applications or with a nut. **Technofast** offers an enclosed nut which prevents ingress of contaminants further increasing the **CamBolt** systems service life.



Special Tensioner



Multi start thread allows for speedy connection.



**technofast**  
precision engineered solutions



Mineral processing screen application.

## Applications

The **CamBolt** is suitable:

- When accurate and reliable loading is required.
- When confined spaces are an issue, incl. restricted bolt spacing.
- In corrosive environments.
- When other types of hydraulic tensioners may be affected by high temperatures.

## A few examples of applications are:

- Attaching exciter mechanisms on mineral processing screens.
- Pressure Vessel Closure (i.e.: Autoclaves, Boilers, etc).
- Crusher Liner Bolts.



Mineral processing screen application.

For details of the other products available from Technofast, please visit our Website [www.technofast.com](http://www.technofast.com)

Technofast Industries  
667 Boundary Road,  
Richlands 4077  
Brisbane Australia

Tel: +61 7 33751431  
Fax: +61 7 33759094  
sales@technofast.com  
www.technofast.com



# CamBolt for Vibrating Screens

## How it Works

The patented *CamBolt* Tensioning system works by using a *CamBolt* to replace the normal nut & washer on an application. To tension the *CamBolt* a Special tool design to fit the majority of vibrating screens used in Mineral Processing plants.

The multi-start thread on the puller adaptor of the Tensioner (1) latches to the *CamBolt* Assembly (2) with only one and a half turns, ensuring speedy installation and removal.

The tensioner is pressurised to achieve the required load.

The locking device is then activated by rotating the bottom section of the *CamBolt*, until the load gap is closed.

The Hydraulic pressure is then released and an optional protective cover fitted to reduce environmental impact.

## Special Spring Return HydraJac with 'CamBolt' Adaptor

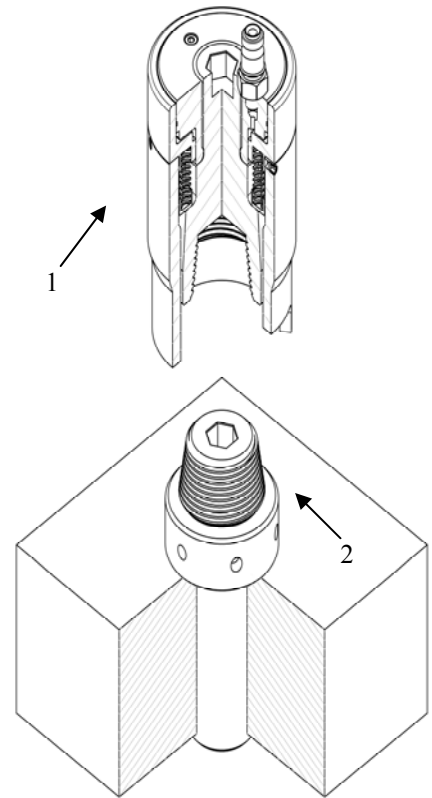

CamBolt

**Technofast Industries Pty Ltd** is an award winning precision engineering company, specialised in the design & manufacture of Hydraulic Nuts, Bolts, and Tensioning devices.

**Technofast** is based in Richlands, QLD and is proud to be an Australian Manufacturer.

The **Technofast CamBolt** is of proprietary design (PCT/AU2005/000254) and protected by Australian and international Intellectual Property law.



Technofast Industries  
667 Boundary Road,  
Richlands 4077  
Brisbane Australia

Tel:+61 7 33751431  
Fax:+61 7 33759094  
sales@technofast.com  
www.technofast.com

**Technofast Technology is:**

**Fast ~ Accurate ~ Cost Effective ~ Safe ~ Simple**